

AEROBASE 3

AEROBASE SERIES



The inflatable Aerobase 3 shelter inflates in minutes and packs away even faster. The hybrid frame is stable in the wind and the main airframe structure eliminates the risk of broken poles. The 3.5 x 3.5m size is our most popular shelter layout, striking a balance between a large shaded area and a low weight and pack size. The Aerobase 3 also mates well with our Evo series tents using an Evo Link.

1 INCLUDED WALL

2,000 MM

2 YR GUARANTEE

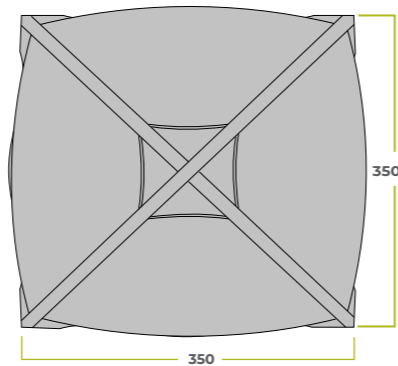

COMPATIBILITY & ACCESSORIES

Aerobase Link, Connectors, Additional Deluxe Side Walls, Roof Cover, Ground Sheet, Supercell Pump, Hurricane Pump

SPECIFICATIONS



FRAME MATERIAL

Inflatable AirSystem tubes, Fibreglass 11.0mm

FLY FABRIC

300D poly oxford (roof), 150D poly oxford (walls)

WATERHEAD RATING

2,000mm

PEAK HEIGHT

2.5m

INTERNAL FLOOR AREA

12.3m²

UV RATING

SPF 50

PRODUCT WEIGHT

15.8kg

PACKED DIMENSIONS

70x42x42cm

PRODUCT CODE

0160350-00000

FEATURE LIST

FRAME

- Single point inflation
- Dome design
- Welded cross tube
- Double seal boston valve
- Semi-geodesic
- Stabilising brow poles
- External inflation points
- Inflatable air frame
- Guide straps

FABRIC

- PU tape seam seal
- Fire retardant treatment
- UV treatment
- Heavy duty 300D canopy
- Torrential rain tested

FLY

- Integrated air frame
- Vertical side walls

WINDOWS

- Adjusted internally
- Fully enclosed internal covers
- Bug proof mesh
- Waterproof window covers

STORAGE

- Integrated storage pockets

CONFIGURATION

- Full head height

ZIPPERS

- Glow zip pullers
- Two way zipper heads

LIGHT RIGGING SYSTEM

- Awning area power cord rigging
- Awning area lantern attachment

PUMP

- Double action
- Pressure gauge
- Pressure release valve
- Carry bag included

WALLS

- Vertical
- Zip on wall attachment
- 1x wall included
- Mesh window
- Internal window covers
- Dual zipper entry

VENTILATION

- Upper expel vents

GUY ROPES

- 3.5mm polyester cord
- Aluminium tri sliders
- Low stretch
- Triple point guy rope connection

CARRY BAG

- Zip closed carry bag
- Durable poly oxford material
- Gusseted carry bag
- Instruction window sleeve

PEG POINTS

- Moulded D ring peg points
- Webbing peg points
- Adjustable peg loops

STABILISING BROW POLES

Prevents the tent from twisting, provides additional stability in the wind, and also increases internal headroom.

INFLATABLE AIR FRAME

More durable and stable than traditional pole systems. Inflatable frames are fast to set up and even faster to pack away.



INCLUDED DELUXE WALL

Zip on wall as a windbreak or to enclose your shelter. Features a large internally controlled window with both solid and mesh options.



UPPER EXPEL VENTS

Upper vents allow warm humid air to escape, minimising condensation build-up.

AWNING AREA LANTERN ATTACHMENT

Hi-vis webbing strap with quick release buckle provides a secure attachment point for a lantern inside the awning.



ZIP ON WALL ATTACHMENTS

A secure and protected attachment point for either a wall, connector or link.

